

Weighing Machines

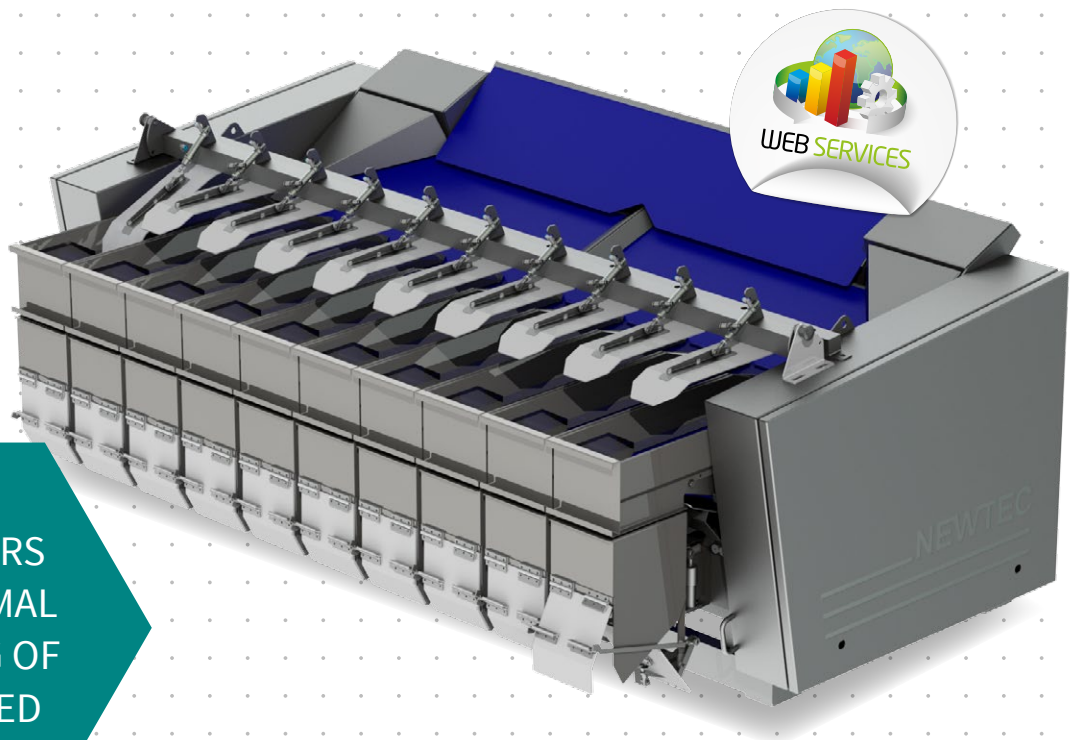

WITH
CONVEYORS
FOR OPTIMAL
HANDLING OF
UNWASHED
PRODUCTS

NEWTEC WEIGHING MACHINE 4010XXB1CI

Application: Unwashed products such as:

- Potatoes
- Beetroots
- Similar products

Advantages:

- High weighing accuracy: Typical giveaway: less than 0.2%
- High speed – up to 20 portions/min. at 25 kg
- All product conveyance is handled by the conveyor belt to avoid build-up of dirt
- WebServices enabled for remote servicing and for capturing production data
- MachineLink enabled - from only one touchscreen, either on our Weighing Machine or Check Point, recipe change and start/stop for both machines is possible

Weighing Machines

NEWTEC WEIGHING MACHINE 4010XXB1CI

EASY ACCESS FOR CLEANING AND SERVICE

Your advantages

- Easy access for cleaning and service
- Protection class: IP54
- Conveyors with individual motors to feed product into each weigh head

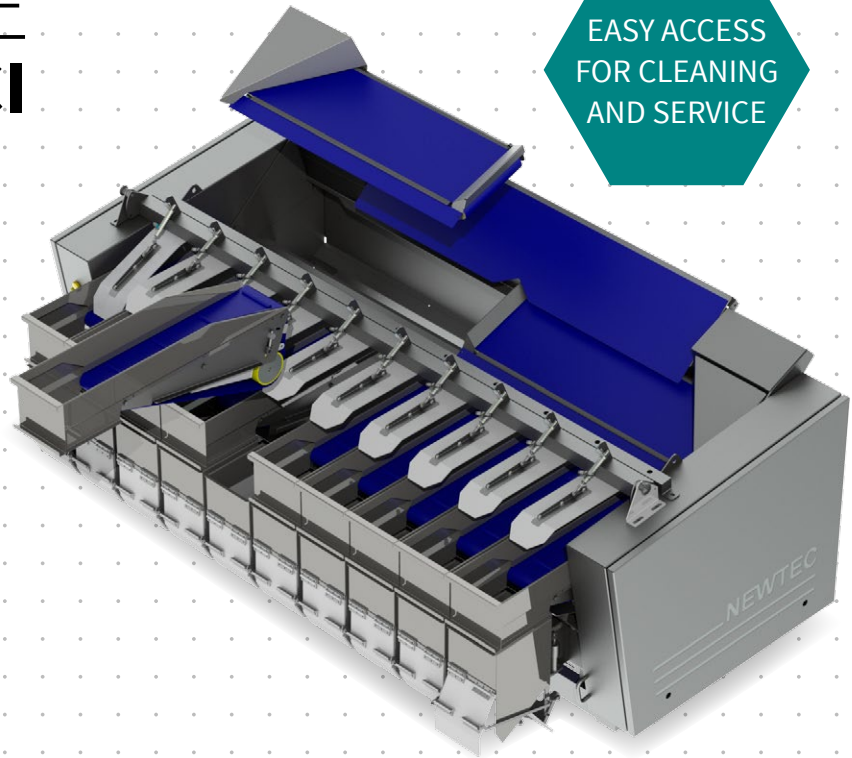

Newtec software

- Intuitive user interface
- Informative and future-proof
- Same user interface on all Newtec weighing and packing machines

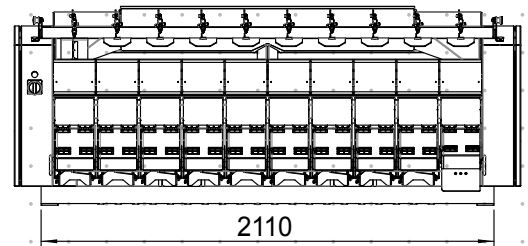
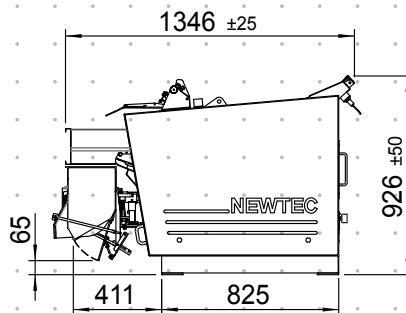

Combination weigher with 10 channels

- Speed:** High speed – up to 20 portions/min. at 25 kg
- Capacity:** 1-25 kg (depending on product)
- Weigh pan volume:** 9 L
- Material:** According to the EU rules on food contact materials
- Air requirement:**
- Connection: 3/8"
- Min. pressure: 6 bar (0.6 Mpa)
- Consumption: 100 NL/min.
- Electrical requirement:** 3x320 VAC or 3x400 VAC (N) PE 60 Hz 6 kW
- Environment:** 5 °C – 40 °C
- Weight:** 690 kg (excl. Portion Collection System)

